

ZK 150 HE

Technical details

Zyklus
made by Pemat



ZK 150 HE

Zyklus Rotating Pan Mixer

Zyklus
made by Pemat

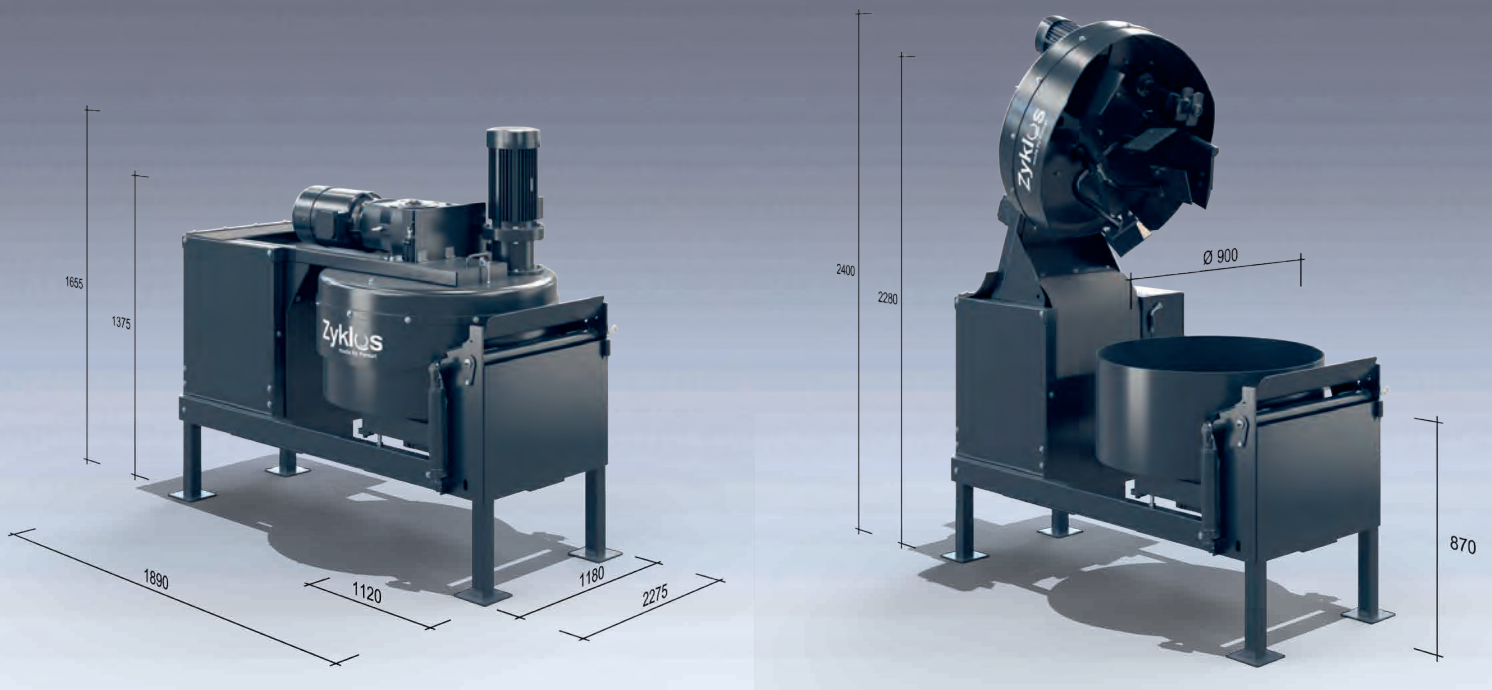

ZK 150 HE

Zyklus Rotating Pan Mixer from Pemat

Technical details

Batch capacity (standard concrete) ready-mix approx. l	150
Dry Filling (max.) approx. l / kg	170 / 240
Mixing pan diameter mm	900
Mixing pan design	hydraulically tiltable
Tilting arm design	hydraulically
Skip design	hydraulically
Power mixing star kW	4
Power hydraulic kW	1,5
Power mixing pan kW	1,5 (optional)
Power tiltable mixing pan kW	–
Pneumatic	–
Voltage V	400
Frequency Hz	50
Weight approx. kg	800